

FILTRABOX



PREMIUM ENGINEERED FUME EXTRACTORS

COMPACT^XDTF

PRODUCE QUALITY DTF TRANSFERS FOR GARMENTS AND OTHER SUBSTRATES IN A CLEAN AIR ENVIRONMENT

REINFORCED LIQUID FILTERS
PROTECTED ELECTRONICS
LARGE LIQUID RESERVOIR
ULTRA-SLIM



Distributed by

DTG
PRO

Specifications

Compact X DTF

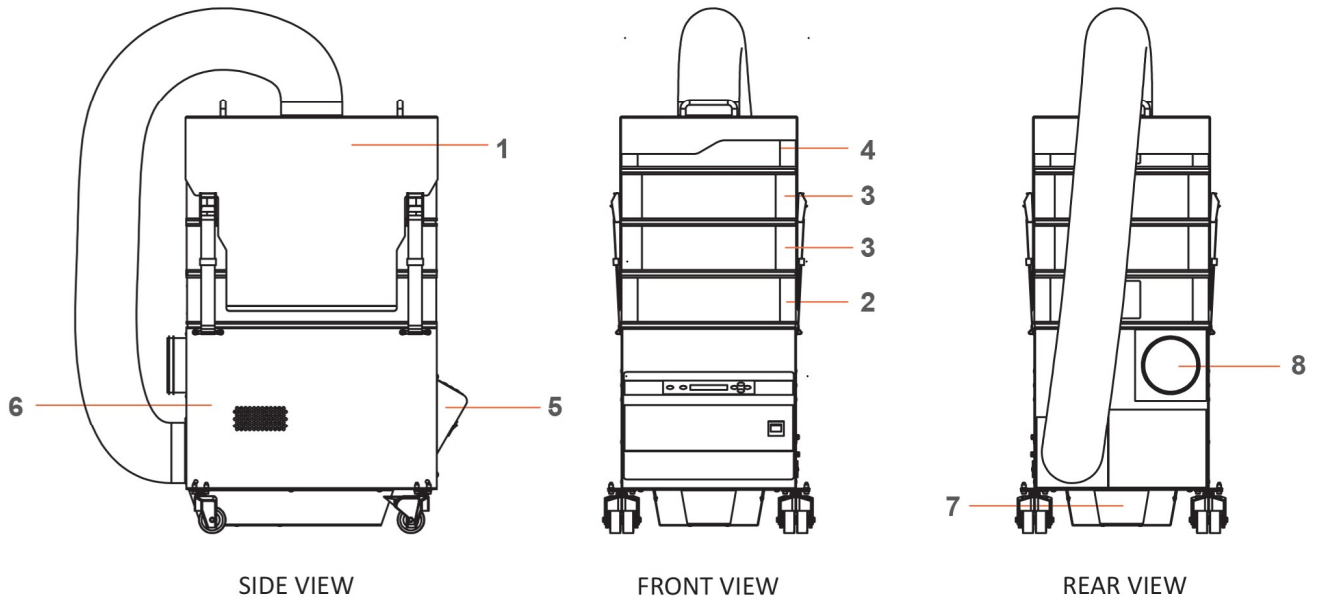

Technical Specification		
Quiet Operation	57 dB	
Max. Airflow	235 CFM	
Height	35 in.	
Width	15 in.	
Depth	29 in.	
Warranty	1 year	
Included Filters		
Type	Material	Total Media
1 Foam Pre-Filter	Washable Foam	13.25 L
2 Hydrophic HEPA	Hydrophobic Polymer (Pleated)	12 m ²
1 Chemical Cartridge Filter	Pelletized Carbon	14 lbs.
Electrical		
Volts	230/120 V	
Frequency	50-60 Hz	
Rated Amps	6/12 A	

Contact us for details on hose kits.

Legend

- 1) Lid Module
- 2) Pre-Filter Cartridge
- 3) HEPA Filter Cartridges
- 4) Carbon Filter Cartridge
- 5) Electronics Module
- 6) Blower Module/Liquid Reservoir
- 7) Exhaust Outlet
- 8) Inlet Spigot

Distributed by



www.dtgpro.com | 626.377.4189

TABLE OF CONTENTS

- i. **INTRODUCTION** – pg. 3
- ii. **SPECIFICATIONS** – pg. 4
- iii. **MACHINE DIAGRAM** – pg. 5
- iv. **MACHINE DIAGRAM: USER INTERFACE** – pg. 6
- v. **MACHINE DIAGRAM: MODULES** – pg. 6
- vi. **ASSEMBLY INSTRUCTIONS** – pg. 7
- vii. **INSTALLATION INSTRUCTIONS** – pg. 8
- viii. **QUICK START INSTRUCTIONS**
 - a. CALIBRATION – pg. 9
 - b. AIRFLOW SETTING – pg. 10
- ix. **LIQUID RESERVOIR DRAINING** – pg. 12
- x. **FOAM PRE-FILTER WASHING RECOMMENDATIONS** – pg. 13
- xi. **FILTER REPLACEMENT INSTRUCTIONS**
 - a. CHECK FILTER WARNING – pg. 14
 - b. FILTER CHECK FEATURE - pg. 15
 - c. REPLACING THE FILTERS – pg. 16
- xii. **ELECTRONICS MODULE REPLACEMENT** – pg. 17
- xiii. **SETTINGS**
 - a. OPERATING MODE – pg. 18
 - b. FILTER CHECK – pg. 19
 - c. NEW APPLICATION CALIBRATION – pg. 19
 - d. SERVICE MENU – pg. 19
- xiv. **EZ-LINK CONTROLLER SET-UP AND PIN-OUT** - pg. 20
- xv. **SUPPORT** – pg. 22
- xvi. **WARRANTY** – pg. 23

INTRODUCTION

Thank you for purchasing the premium engineered Filtrabox Fume extractor. Its modular construction allows for high performance, easy serviceability and longer life. In addition, the new "slim-line" design reduces the width of the extractor for the most efficient floor layouts.

Servicing and maintaining the Filtrabox is a snap. The machine is made up of modular parts, making it easy for you to swap-out and swap-in any module by fastening a few screws and snapping a few cable connections per module.

SPECIFICATIONS

	Compact X DTF
Voltage	120V / 240V
Frequency (Hz)	50 / 60
Max Current (A)	12/6
Blower Type	1x Brushless
Depth (mm/inches)	736.6/ 29
Width (mm/inches)	381 / 15
Height (mm/inches)	991 /39
Weight (kg/lbs)	45/99
Max Flow (CFM)	235
Pressure: (in. H₂O)	42 (High Pressure)
Construction	Steel
Design	Modular/Independent Filters
Operating Decibels	57
Display/Control	LCD/Membrane Keypad
Flow Control	Auto-Compensation
Warranty	1 year
1x Pre-Filter	<p>Foam Prefilter</p> <p>P/N: FIL-P-CX-477</p>
2x HEPA Filters	<p>Hydrophobic HEPA Cartridge Efficiency: 99.5% @ 0.3</p> <p>Media: Hydrophobic Polymer Filtration Area: 6m²</p> <p>P/N: FIL-P-CX-457</p>
1x Gas Filter	<p>Gas Phase Cartridge Filter Media: Activated Carbon Media Weight: 22 lbs</p> <p>P/N: FIL-G-CX-447</p>

MACHINE DIAGRAM

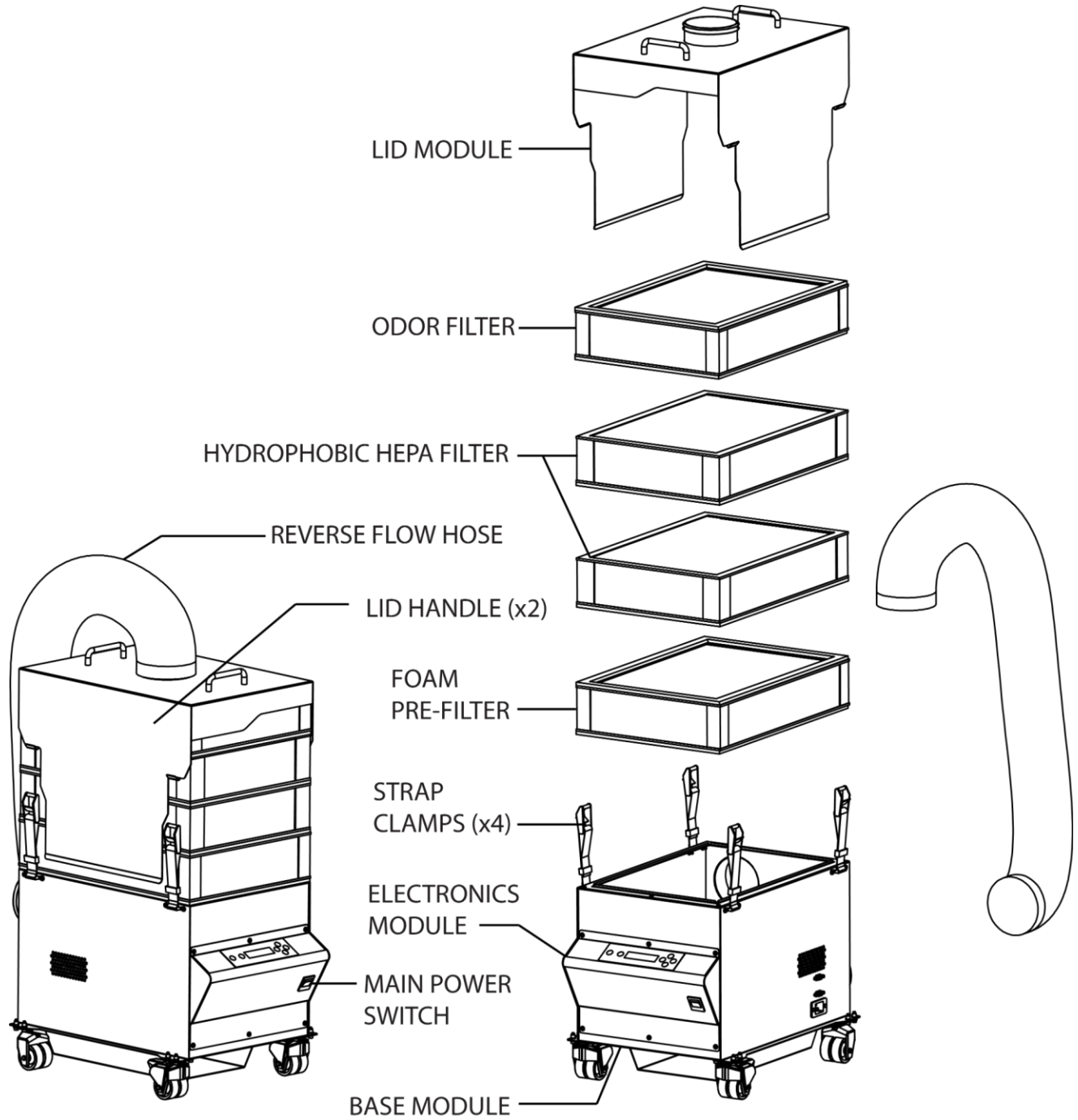

MACHINE DIAGRAM – USER INTERFACE

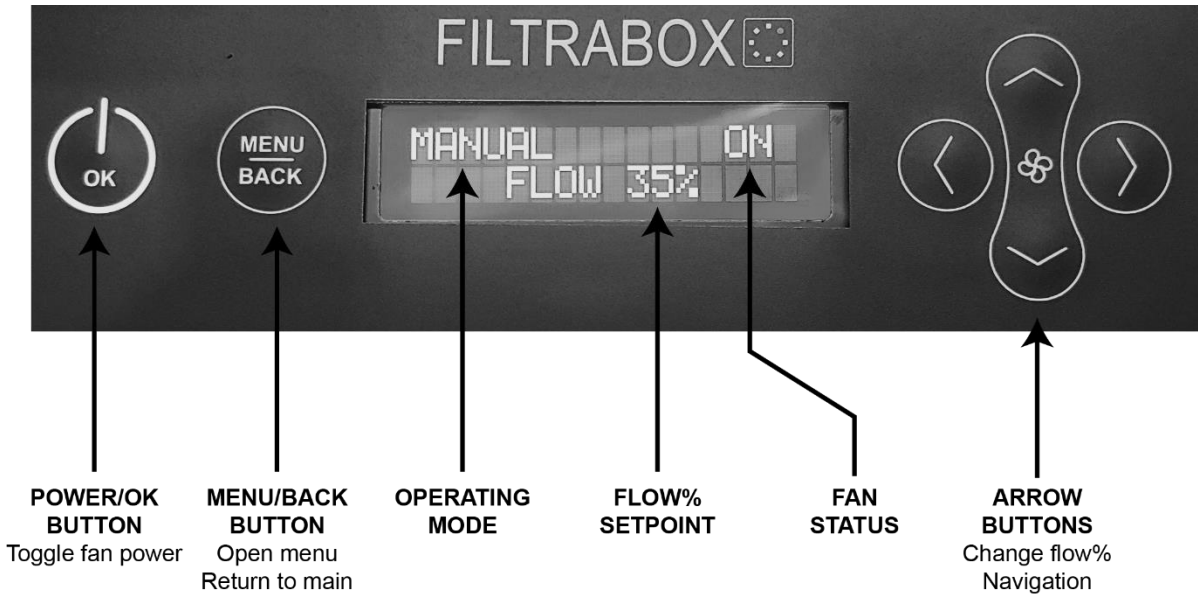

MACHINE DIAGRAM – MODULES

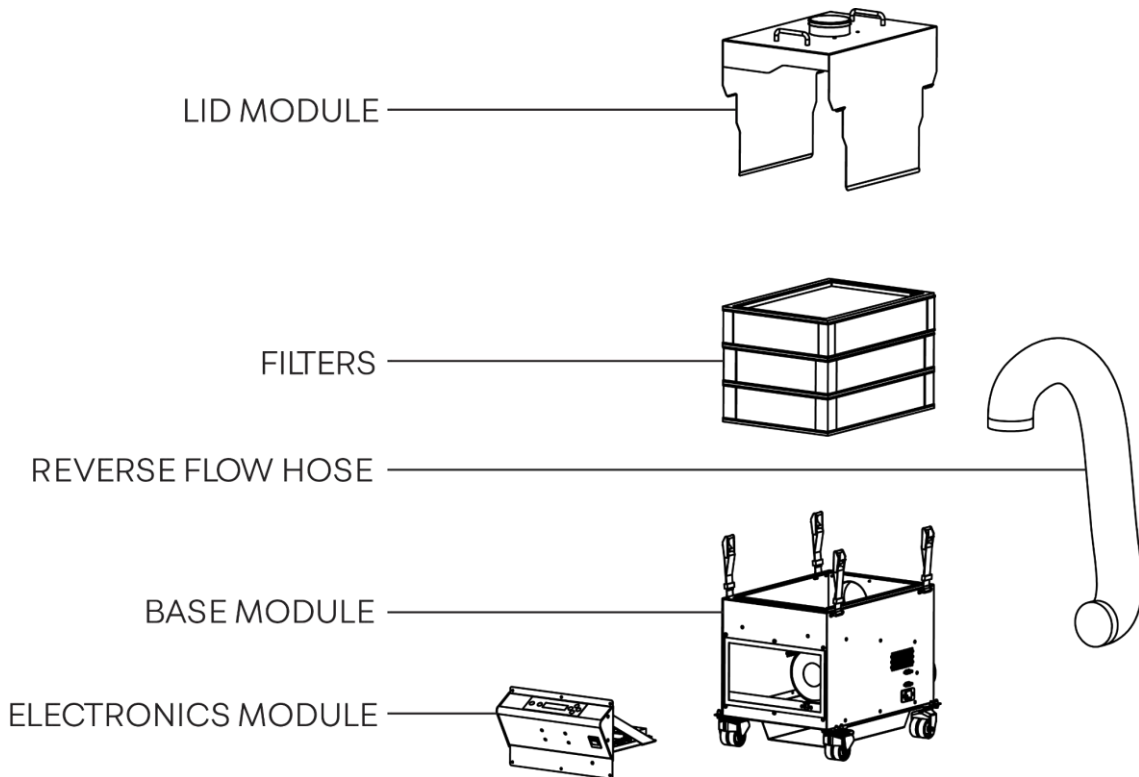

ASSEMBLY INSTRUCTIONS

UNPACKING

! Useful Tip: The Filtrabox is shipped in custom packaging for maximum protection during transport. Consider keeping the packaging should you wish to ship the product again.

! Attention: The Carbon Odor Filter is HEAVY. Each filter weighs approximately 50lbs. Take appropriate care and precaution when lifting the filter.

Take inventory of the parts included with your kit:

1. *Main Chassis*
2. *1x Foam Prefilter*
3. *2x Hydrophobic HEPA Filters*
4. *1x Carbon Odor Filter*
5. *Lid Module*
6. *Reverse Flow Hose*
7. *Connection Flex Hose: 4" diameter x 8 feet with hose clamps*
8. *Hi-Temp Flex Hose with hose clamps*
9. *Bleed-air Coupler*
 - a. *Other hose adapters are optional*
10. *Power Cord: rated to 15 amps*

INSTALLATION INSTRUCTIONS

! Important Note: The Calibration system will take all the bends and restrictions of the flex hose into account and provide optimal performance.

1. Install one side of the **4" Flex Hose** onto the inlet of the Filtrabox.
2. Install the **Hi-Temp Flex Hose** onto the **bleed-air coupler** with a **Hose Clamp**. Install the other side of the **Hi-Temp Flex Hose** onto the outlet of the DTF oven. Secure it with the supplied **Hose Clamp**.
3. Secure the other end of the supplied **Hi-Temp Flex Hose** to the DTF oven with the supplied **Hose Clamp**.
4. Install the supplied power cord onto the back of the Filtrabox and turn it on with the **Main Power Switch** located at the bottom of the **User Interface**.
5. Place the Filtrabox in the final position that it will be regularly used. This is important for **Calibration** as the system will take all the bends and flow restrictions of the flex hose into account and provide optimal performance. Engage the brakes on the two front wheels to hold the machine in place.

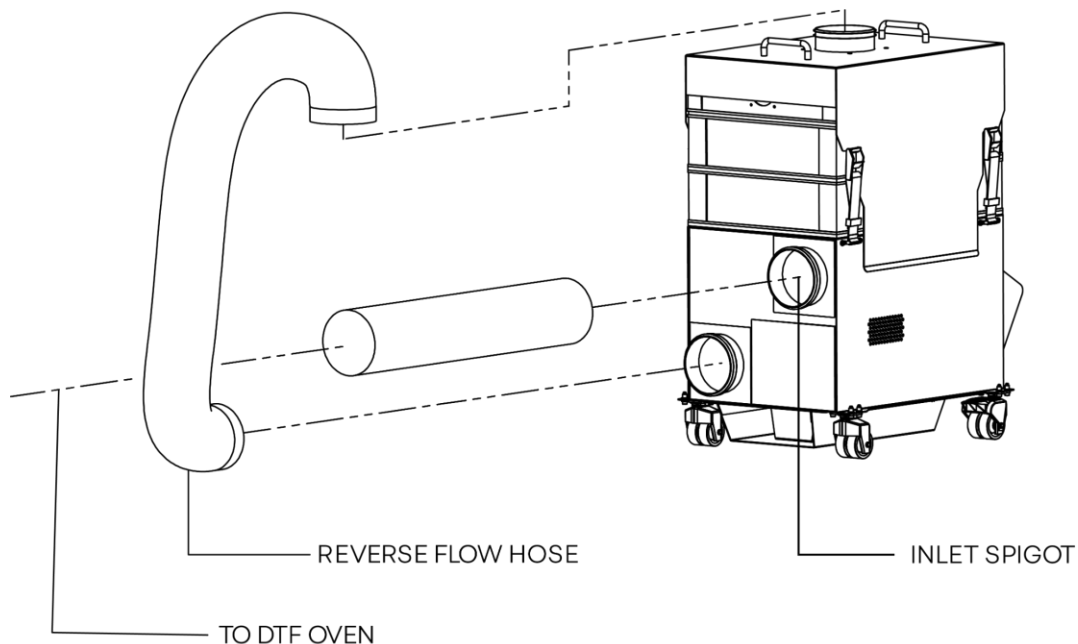

QUICK START INSTRUCTIONS:

CALIBRATION & AIRFLOW SETTING

SAFETY

! Before connecting the device to a power source, ensure that the main power switch in the rear of the device is in the off position “0”.

! Avoid plugging or unplugging the unit while it is powered ON (“I”).

CALIBRATION

! Device must be calibrated to your specific DTF set-up to function properly and ensure longer filter life.

Once the Filtrabox has been turned on, the screen will prompt, “Press Ok to Calibrate”. Before pressing OK, follow the instructions below:

1. First, hook up the Filtrabox fume extractor to the DTF oven, with the supplied hose or with the hose you intend to permanently use for the application. Arrange the DTF oven, Filtrabox and the hoses into their desired locations. *This is important because the calibration process takes the restrictions caused by the bends in the hose and positioning of the equipment into account.*
2. ***! Pressing the “OK” button will trigger the Calibration process which will take approximately one minute. If the system asks how many blowers, enter “1” for the Compact DTF. Once the calibration is complete, you never have to calibrate again unless you change your set-up for a new application. If the calibration process fails, try restarting the system and ensuring that nothing is obstructing the inlet or hose. If the calibration process continues to fail, contact Filtrabox Technical support for help.***
3. In the future, if you wish to Calibrate Filtrabox to a new application, press the “Menu” button. Press the right arrow key to advance the screen until you reach the “New Application Calibration” section. Press the “OK” button to initiate Calibration. *The Calibration process will take approximately one minute. (A new application is defined as a different set-up that would change the airflow restrictions of the system. For example, different diameter, length or bends of hoses and/or different ovens.)*

AIRFLOW % SETTING

! USEFUL TIP 1:

Set your “Airflow %” to the lowest possible setting that will adequately evacuate the fumes from your DTF oven. This ensures that you are using your filters to their maximum potential which minimizes costs.

! USEFUL TIP 2: *Start by setting your Filtrabox at 10% and incrementally increase up from there until fume no longer emanate from the transfer film entrance and exit slots in the oven.*

SETTING THE AIRFLOW% SETTING

1. The Status screen is the first screen shown once the device has finished calibrating or finished booting up. The device will display the current flow setting.
2. Turn on the blower by pressing the “Power” button while in the “MANUAL” setting.
3. Set the “Airflow %” to the desired starting point by pressing the “UP” or “Down” buttons.
4. Start running the DTF system on the most fog generating print size and type you will typically use.
5. Adjust the “Airflow %” until you see that no fog escapes from the film entry and exits of the oven.
6. Continue adjusting your flow until you are satisfied with the performance. The “Airflow %” value will be automatically saved to memory.

! The AUTO-COMPENSATION FLOW CONTROL feature, which is standard on the Filtrabox, will maintain the set-point “Airflow %” by automatically increasing power to the blowers as the filters get obstructed. You do not have to manually change the “Airflow %” setting again.

When the DTF oven is not in use, press the “Power” button to turn the blower(s) off.

7. Filtrabox has an EZ-link feature that allows you to turn the blowers ON or OFF remotely from the oven (if this feature is available on your oven). See the EZ-LINK section of the manual.

**YOUR FILTRABOX DTF EXTRACTOR IS NOW
SET-UP FOR OPERATION.**

LIQUID RESERVOIR DRAINING

ATTENTION!!!

Avoid skin and eye contact. Exposure may irritate the skin and eyes. Use goggles (or face shields) and rubber gloves when handling liquid.

Liquid can build up in two reservoirs within the Filtrabox. Regularly draining these reservoirs is essential to maintain good filter life and prevent unwanted mess and maintenance.

DRAINING INSTRUCTIONS:

1. Power off the Filtrabox before any maintenance is done.
2. To empty the main reservoir, place a container under the drain valve located at the back of the Filtrabox and turn it to the open position. Allow the reservoir to drain into the container then close the valve and dispose of any liquid.
3. To empty the lower reservoir, place a container under the drain plug located on the bottom of the Filtrabox. Remove the drain plug by unscrewing it. Allow the reservoir to drain into the container then replace the plug with its rubber washer and dispose of any liquid.
4. Ensure that the main drain valve is closed and the lower drain plug is installed with its rubber washer before turning the Filtrabox on.

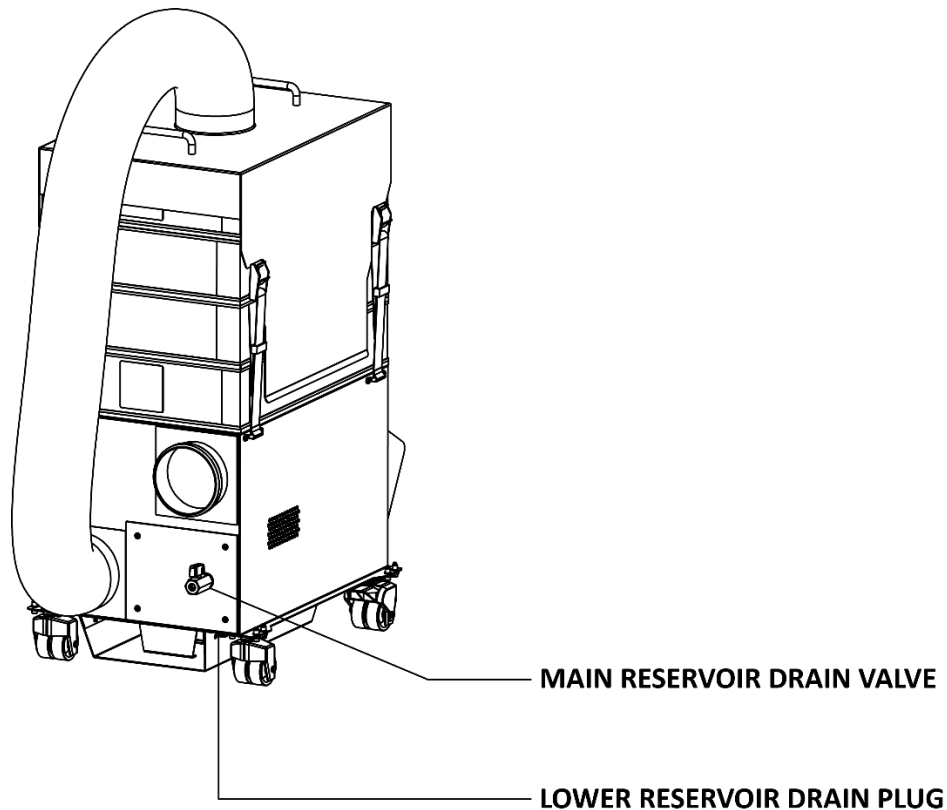

FOAM PRE-FILTER WASHING RECOMMENDATIONS

ATTENTION!!!

Avoid skin and eye contact. Exposure may irritate the skin and eyes. Use goggles (or face shields) and rubber gloves when handling and washing used filters.

The foam pre-filter is washable in warm water. Please note that the prefilter will take several days to dry. Using the prefilter while still wet after washing will reduce its effectiveness and the overall performance of the extraction system (not recommended). We recommend purchasing a spare foam prefilter. Having two prefilters lets you dry one in a bucket while using the other prefilter in the system for uninterrupted use of the fume extractor.

WASHING INSTRUCTIONS:

5. Use an appropriately sized container to soak the foam pre-filter in warm, clean water. Saturate the filter with water.
6. Firmly wring the filter out to remove the excess water from the filter. Do not allow the foam filter to touch the excess water to avoid re-absorption into the foam. Dispose of the waste wash water.
7. Repeat the process two more times. Always use clean water each time.
8. Orient the foam filter vertically and place it in a large open bucket. Make sure that the filter is not touching the bottom of the bucket. Allow enough space between the filter and the bottom of the bucket to prevent the reabsorption of the drained wastewater into the foam. Leave the filter in the bucket to drain and dry out for at least five days in a dry environment. Once fully dry, reinstall the filter into the extractor or store it in a dust-free, dry, ventilated environment.

FILTER REPLACEMENT INSTRUCTIONS

ATTENTION!!!

When the “Check Filter” warning comes on, do not try to manually increase the set-point Airflow %. Changing this value WILL NOT increase actual airflow. “AUTO-COMPENSATION FLOW CONTROL” is already applying maximum power to the blowers. Simply change the filters and normal operation will resume.

“CHECK FILTER” WARNING

! Replacement filters can be purchased from: www.dtgpro.com

The “**Check Filter**” warning will appear on the screen when either Pre-Filters and/or the HEPA filters need replacement.

To determine which filter needs changing, use the “**Filter Check**” feature. See below.

“FILTER CHECK” FEATURE

! Replacement filters can be purchased from www.dtgpro.com

NOTE: HEPA FILTERS SHOULD ALWAYS BE TESTED AS A PAIR.

9. If the “**Check Filter**” warning comes on, go to the **User Interface** and press the **MENU** button. Press the **UP or DOWN** keys to scroll through the menu functions until you find the “**Filter Check**” feature.
10. Press the **OK** button to initiate the “**Filter Check**” process; follow the prompts on screen.
11. Filtrabox will first assess the status of the **Pre-Filter**, the machine will then display a prompt to remove the **Pre-Filter** (refer to image below).
12. **IMPORTANT!** Loosen both **Strap Clamps** on the **Lid** by pressing the lever on the clamps. Unhook the **Strap Clamps** and remove the **Lid** by lifting it straight up off the assembly.
13. Remove the bottommost filter (**Pre-Filter**) and set it aside, then put the **Lid** back onto the **two HEPA Filters** as in the image below. Hook the **Strap Clamps** back onto to the **Lid** and endure that they are tight.
14. Follow the prompts on screen so the Filtrabox can finish the procedure.
15. Filtrabox will then advise you to replace **either the HEPA or the Pre-Filter** depending on their condition. If the filters are still in good condition, a **Filter Life %** will be displayed.
16. When the filter check is complete, replace the **Pre-Filter** and make sure that the **Strap Clamps** are tightened.

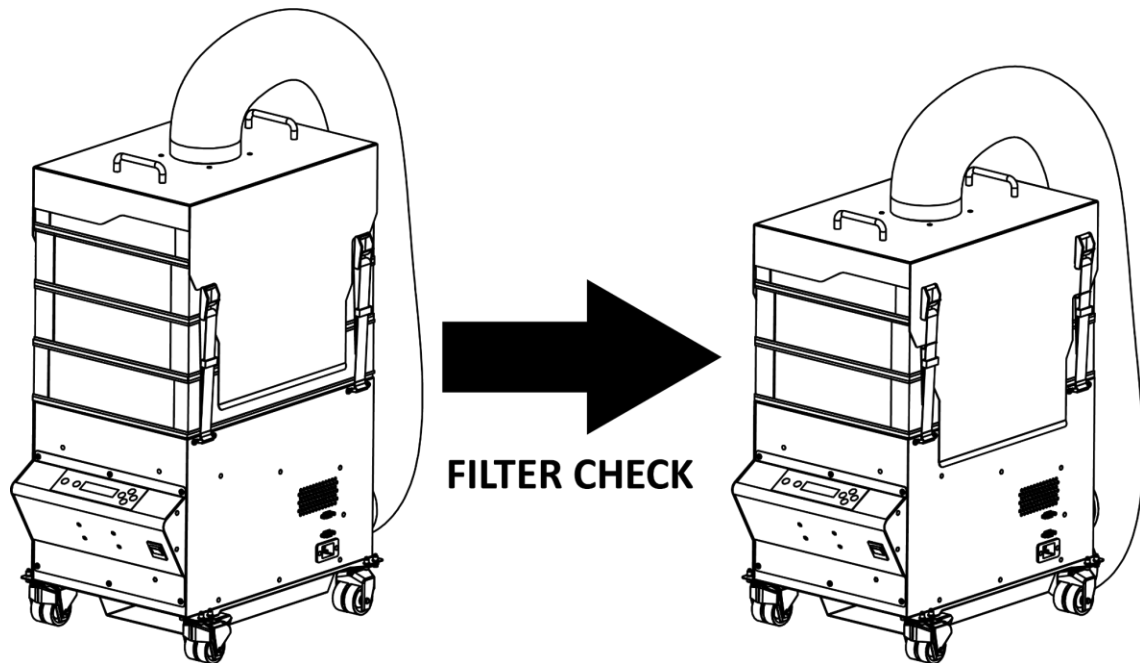

REPLACING FILTERS

! Replacement filters can be purchased from www.dtgpro.com

NOTE: HEPA FILTERS SHOULD BE REPLACED AS A PAIR.

Once you have identified which filter needs replacing, follow these steps to access the filters. If you haven't done a "Filter Check", see the steps above before removing filters.

1. **IMPORTANT!** Loosen both **Strap Clamps** on the **Lid** by pressing the lever on the clamps. Unhook the **Strap Clamps** and remove the **Lid** by lifting it straight up off the assembly. You now have access to the filters.
2. The filters are arranged in a stack. The bottom most filter is the Pre-Filter, the middle filters are the two HEPA filters and topmost filter is the Carbon Filter. Carefully unstack the filters to access the filter you are wanting to remove.
3. Replace the filter and restack the filters onto the base as described in step 2.
4. Put the lid back on and tighten all four straps to ensure that the lid, filter stack and base are well sealed.
5. If you observe an increase in odors, replacing the carbon filter may be necessary.

ELECTRONICS MODULE REPLACEMENT

! To avoid any risk of electrical discharge, turn off and unplug the Filtrabox before doing any activities that require disassembly of the unit.

The **Electronics Module** houses all the main electrical components and the main electronics assemblies. In the event of damage or a malfunction, the entire module can be removed from Filtrabox by removing a few screws and disconnecting a few cables. Contact Filtrabox to order.

1. **!IMPORTANT!** Ensure that the Filtrabox is powered off and unplugged.
2. Remove all six Phillip's-head screws holding the **Electronics Module** in place.
3. Pull the **Electronics Module** out and place it on the floor in front of the machine with all the wires still connected.
4. Disconnect all five wires that connect the **Electronics Module** to the rest of the machine:
 - a. The large white 5-pin connector
 - b. The two wires on the power switch
 - c. The ribbon cable on the main board
 - d. The small 2-pin JST connector
5. Remove the old **Electronics Module** and replace it with the new one by reconnecting the wires that were disconnected in step 4.
6. Insert the new module into the machine and reuse the six Phillip's-head screws to hold it in place.
1. Plug in and power-on the unit, then go to the **User Interface** and press the **"Menu"** button. Press the right arrow key to advance the screen until you reach the **"New Application Calibration"** section. Press the **"OK"** button to initiate Calibration. **The Calibration process will take approximately one minute.**

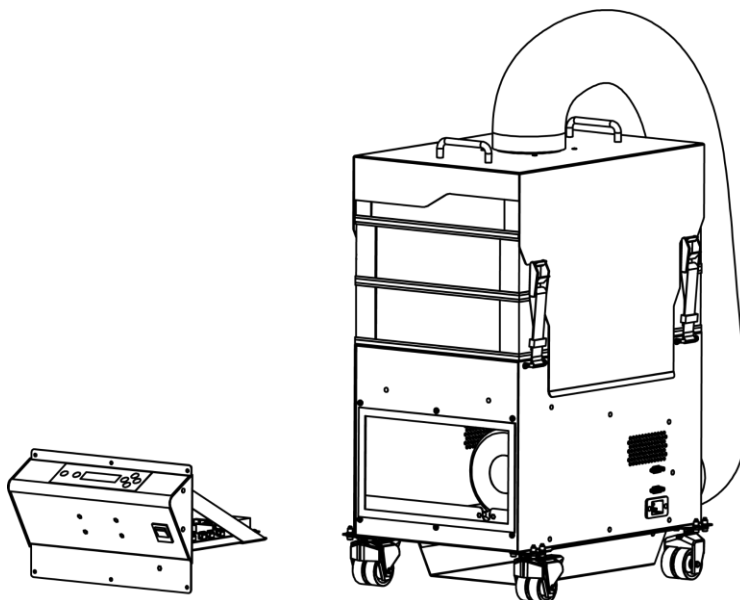

SETTINGS

Press the “Menu” button and then use the “Left or Right” buttons to scroll through the settings menus. Press the “OK” button to select the setting:

OPERATING MODE SETTING

There are **3 Modes of Operation**. In all three modes, the user always controls the “**Airflow %**” setting by simply pushing the “UP or Down” buttons at any time. To select the mode, press the “Up or Down” arrows to scroll the options below and press the “OK” button to confirm your selection.

1. Manual Mode (On/Off)

This mode allows the user to manually choose the on/off state of the blowers in the Filtrabox. This is the default mode. Toggle “**ON/OFF**” by pressing the “**Power**” arrow key. The blower(s) will be engaged to the previously set “**Airflow %**”

2. Link On/Off

This mode uses the **DB9 connection** at the rear of the Filtrabox. The blowers will be engaged at the previously set “**Airflow %**” when DTF Oven requests it. (If feature is available on the oven.) When the Laser does not require any airflow, the system automatically deactivates the blowers. If there is no laser system connected, the blowers will never engage. See the Controller Set-up and Pin-Out example at the end of the manual.

FILTER CHECK SETTING

See the *FILTER CHECK Feature* in *Filter Replacement Instructions*.

NEW APPLICATION CALIBRATION SETTING

! This will initiate the Calibration sequence. Avoid doing this unnecessarily. This should only be used if you are changing DTF systems, length of hose, diameter of hose; or anything that would change (reduce or increase) the airflow restrictions in the entire system. Calibration should only be done with a new set of filters otherwise the filter check feature will not function as intended.

While in the “**New Application Calibration**” setting, press the “**OK**” button to initiate Calibration. *The Calibration process will take approximately one minute.*

SERVICE MENU SETTING

This menu is only to be used by Filtrabox Technicians or with the guidance of a Filtrabox Technician.

EZ-LINK CONTROLLER SET-UP AND PIN-OUT

COMPACT AND EXPAND DB9 PIN-OUT

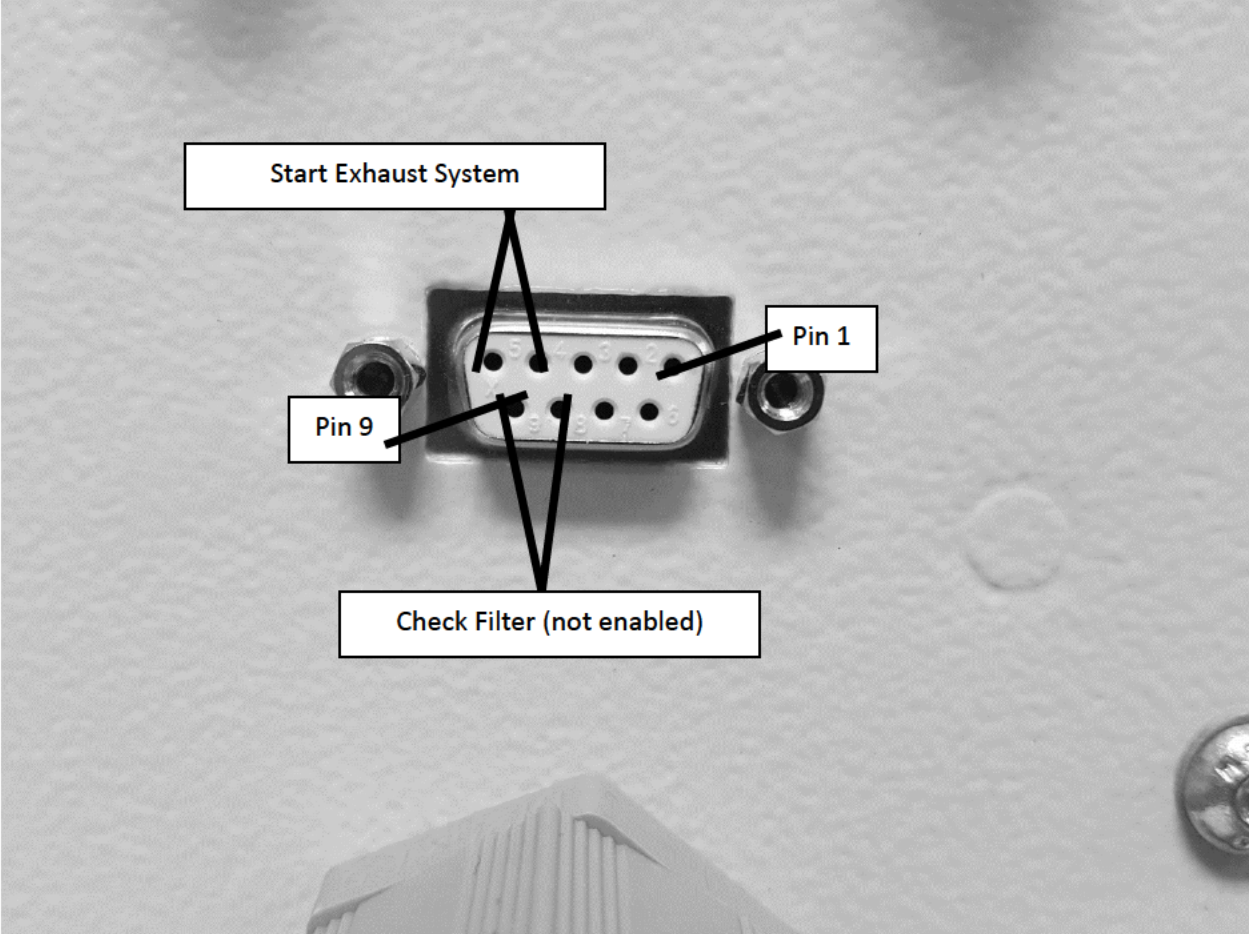

Figure 1: An example of a D-Sub 9 connector COMPACT AND EXPAND

Pins 4 & 5: Normally Open – Output from DTF Controller

The controller connects these two pins to start the exhaust system.

Pins 8 & 9: Normally Open – Input to DTF Controller

The exhaust system will connect these two pins when the filter check status appears on the extractor.

EZ-LINK Electrical Requirements

Figure 2 below shows the required circuit for the output on the DTF filter control system. When the laser's filter control unit wishes to turn on the exhaust system, the contacts on the relay are closed, thus connecting the two output pins. These output pins correspond to pins 4 & 5 on the exhaust system. When creating a circuit to detect when these two wires have been connected, **no more than 200 mA** may pass through these wires.

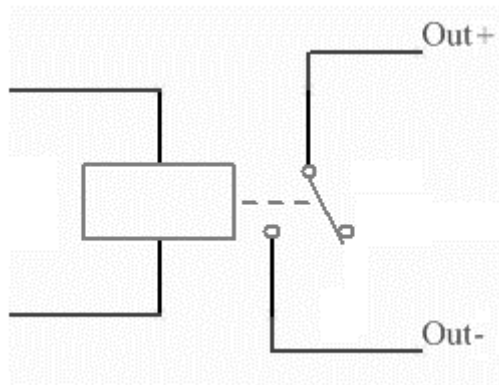

Figure 2: The circuit for the "start exhaust system" signal.

When creating the "Check Filter" signal, the two wires for the signal should be shorted together using a relay. This means that the exhaust system will not actively dump any current through these wires. The DTF's filter control unit should use approximately 30 mA to detect when those wires have been connected.

EZ-LINK Control Operations

The filter control operation is very simple. When a user begins to run DTF Transfer job, the filter controller turns on the exhaust system immediately. When the job has been cancelled, paused, or finished, the DTF's filter control unit should wait 15 seconds or more before turning off the exhaust system. This allows any extra fumes to be evacuated from the DTF oven.